



innovoxaudio.com

Sub-Bass Series –

# SBC-110

## DESCRIPTION

The **SBC-110** is a dedicated high definition subwoofer system designed for permanent installation in 2' x 2' ceiling grids (separate strain relief required). The system uses a single 10" low frequency driver in an optimally vented enclosure.

**SBC-110's** are frequently used as a low-bass component in extended range distributed ceiling-mount audio systems. They also complement the Innovox *Slim Line Series* of slim profile surface -mount loudspeakers and the Innovox *Flex-Video Series* of video display-mounted loudspeakers..

### KEY FEATURES:

- 2' x 2' ceiling grid mounting
- 34 Hz low frequency extension
- minimum clearance (only 10.25 in. high)

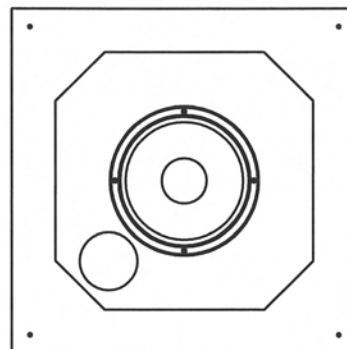

### APPLICATIONS:

- theme venues and restaurants
- media centers
- boardrooms
- video presentation rooms
- retail spaces

## NOMINAL DATA

Frequency Response	34 – 350 Hz ± 3 dB
Sensitivity	91 dB @ 2.83 volts
Impedance	8 Ω
Power Handling	175 W long term program (AES-2)
Maximum Output	112 dB long term; 118 dB peak
Nominal Coverage Angles	omni-directional
Dimensions	height: 10.25 " / 260 mm width: 21.75 " / 552 mm depth: 21.75 " / 552 mm
Net Weight	38 lbs / 17.3 kg
Shipping Weight	42 lbs / 19.1 kg

## DESCRIPTIVE DATA

System Configuration	Dedicated subwoofer
Components & Loading	(1) 10 " cone driver, vented
Recommended High-Pass Filter	4 <sup>th</sup> order Butterworth @ 27 Hz
Cabinet Type	Rectangular with flange for ceiling grid
Enclosure Material	Hardwood multi-ply plywood
Finish	Black or White (custom colors available)
Connectors	Dual binding head screws
Suspension Hardware	(5) 3/8"-16 threaded mounting points located on enclosure top
Grille	Powder-coated perforated steel standard

### West Coast Office

1155-C Arnold Drive, #231  
Martinez CA 94553  
ph: **925 372-8156**  
email: orders@innovoxaudio.com

### Central Office

296 North Pascal Street  
Saint Paul MN 55104  
ph: **612 379-0100**  
email: sales@innovoxaudio.com

innovoxaudio.com